

***3-Axis Vibration Measurement**

***Extreme Small Size & Lightweight (8 Grams)**

***Sensitivity 1.5 pC/g**

***Low Base Strain Sensitivity**

***Electrical Isolation**

***Adhesive Mounting**

The Model 612-TX Triaxial Piezoelectric Accelerometer is designed to meet the most stringent space and mass loading requirements with a weight of only 8 grams and a volume of 0.082 cubic inches.

The 612-TX incorporates miniature shear-type accelerometer inserts bonded into a machined aluminum block. The electrical isolation provided by the epoxy bonding permits accurate, repeatable measurements even in noisy industrial environments. This unit is equipped with the exclusive Columbia microminiature detachable cable assembly that is easily replaced. The Model 612-TXHT is a high temperature version that will operate in environments up to +500 Deg. F. *Consult the factory for customized versions of these sensors.*

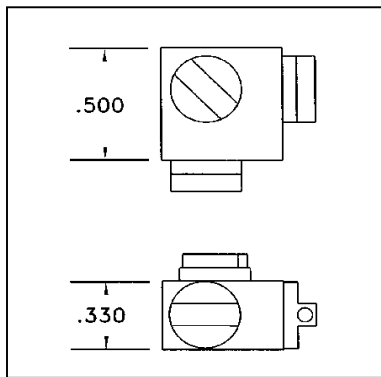
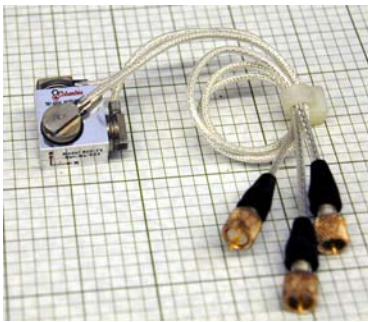

Accessories Supplied:

- (3) Miniature Cable Assembly, LNHT-3 Ft.
- (3) Microminiature Detachable Cable Assy, MMHR-6"
- (3) Double Female Connectors
- (1) Hardwood Storage Case
- (1) Standard Calibration Data
- (1) Certificate of Calibration Traceable to N.I.S.T.

Specifications

Transfer / Electrical	612-TX & 612-TXHT
Charge Sensitivity ¹	1.5 +/-0.5 pC/g
Capacitance	300 +/-60 pF
Frequency Linearity ²	+/-5% Max 2 Hz To 8,000 Hz
Mounted Resonant Frequency	40 KHz, Nom.
Transverse Sensitivity	5% Max
Amplitude Linearity	+/-1.0% (BFSL)
Insulation Resistance	20,000 M Ohm Min, 50 VDC Test
Isolation Resistance	100M Ohm, Min.
Environmental	
Vibration Limit	1,000 g Max (Sine)
Shock Limit	5,000 g Max
Temperature Range	
Model 612-TX	-100 To +350 Deg F (-73 To +175 Deg C)
Model 612-TXHT	-100 To +500 Deg F (-73 To +260 Deg C)
Humidity ³	0 To 98% R.H. (Non-Condensing)
Base Strain Sensitivity	0.002 g/uE Equiv, Typical
Electromagnetic Sensitivity	0.01 g (Equiv / 100 Gauss)
Acoustic Sensitivity	0.01 g RMS (Equiv @ 150 dB SPL)
Physical	
Configuration	Inverted Ring Shear
Size	0.500 In. Sq. x 0.330 In. H (12.7 mm Sq x 8.4 mm H)
Weight	0.28 Oz (8 Gm)
Case Material	Stainless Steel / Aluminum Alloy
Electrical Interface	Coaxial 10-32 Thread
Mounting	Adhesive

NOTES:

- ¹ At +75 Deg F, 10g Peak, 100Hz; Lower Frequency Limit is Determined by Associated Electronics
- ² Referenced to Sensitivity @ 100 Hz.
- ³ With Connector Protected or Sealed, Unit is Epoxy Sealed